

HYVAC PRODUCTS, INC.

MAIL: P.O. Box 389 • PHOENIXVILLE, PA • 19460-0389 • U.S.A.

PLANT: 201 NORTH 5TH AVENUE • ROYERSFORD, PA • 19468 • U.S.A.

610-792-0500 PHN • 610-792-0600 FAX

EMAIL jeff@hyvac.com

INTERNET [HTTP://WWW.HYVAC.COM](http://WWW.HYVAC.COM)

HyVac RG Blowers

HyVac RG Blowers are very simple oil free vacuum pumps for a variety of applications. Typically they perform well to about 16" of HG vacuum (217" H₂O) or about 400 Torr. They have a number of benefits including relatively low noise level and freedom from most maintenance issues. They are also compact and lightweight. They can handle both vacuum and pressure applications although; we are primarily involved with the vacuum side. They are a good choice for replacement of rotary vane or rotary lobe type pumps in high-pressure vacuum applications. They operate at 3600 rpm and come with standard 3 phase TEFC motors.

The RG 85 uses a 3.5 HP motor rated at 10/5 amps. It weighs 88 lbs and has a sound level of 70dB. It is a pulsation less source of continuous duty vacuum pressure.

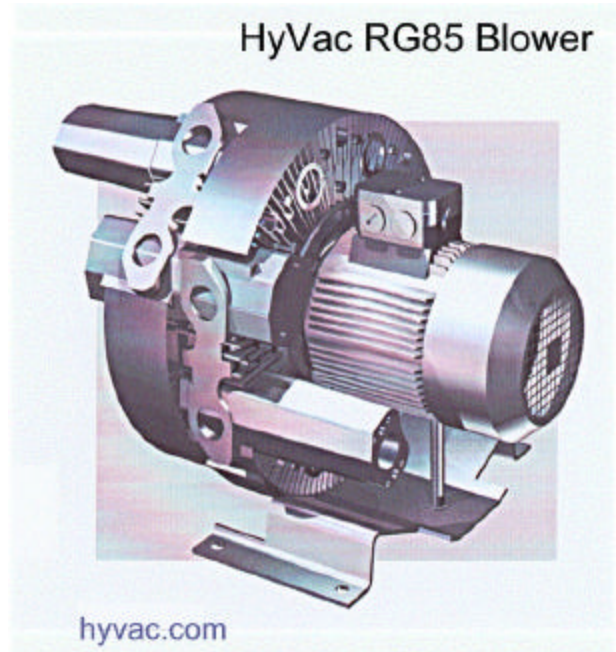

RG85 Dimensions

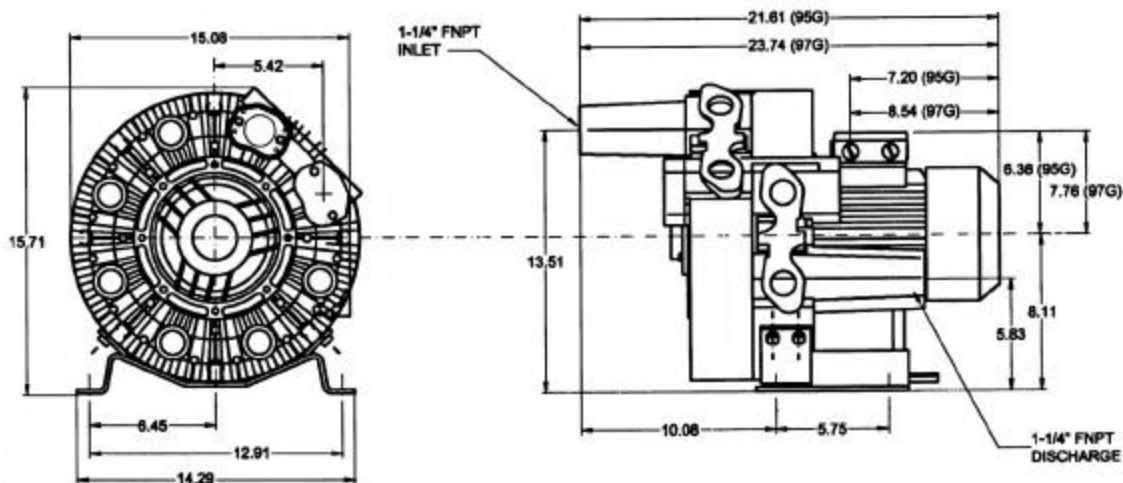

HyVac RG Blowers

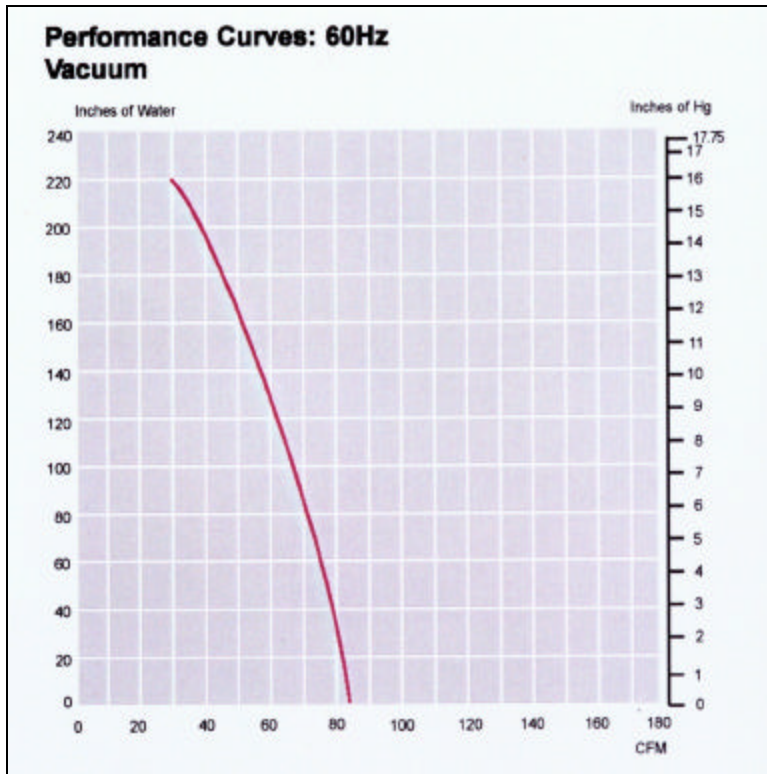

85 CFM at Atmospheric pressure